

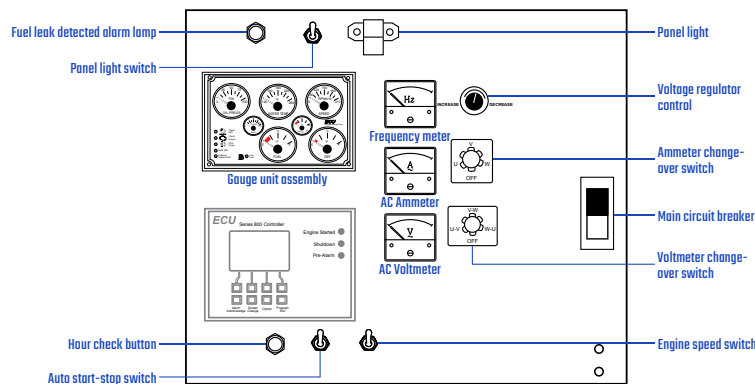

Generator Control Panel

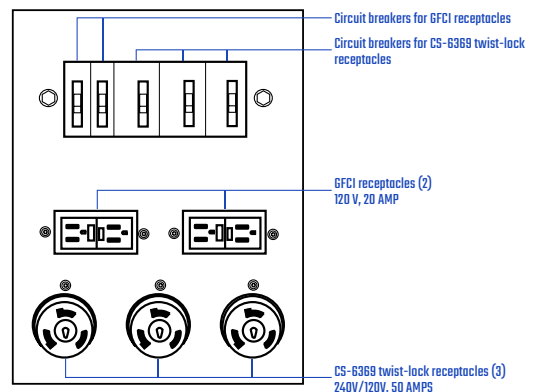

Generator Output Panel



DCA70SSIU4F Weights*

Dry Weight	3,326 lbs. (1,509 kg)
Wet Weight	4,207 lbs. (1,908 kg)
Max. Lifting Point Capacity	6,960 lb. (3,157 kg)

* Weights do not include options

DCA70SSIU4F Dimensions (with trailer)

Length	165.26 in (4197 mm)
Width	71.50 in (1816 mm)
Height	96.57 in (2453 mm)





AXIS
PORTABLE AIR

DCA70SSIU4F

GENERATOR SPECIFICATIONS

56kW

Generator Specifications

Design	Revolving field, self-ventilated Drip-proof, single bearing	
Armature Connection	Star with Neutral	Zig Zag
Phase	3	Single
Standby Output	62 KW (77 KVA)	44 KW
Prime Output	56 KW (70 KVA)	40 KW
3Ø Voltage (L-L/L-N) Voltage Selector Switch at 3Ø 240/139	208V/120, 220V/127, 240V/139	N/A
3Ø Voltage (L-L/L-N) Voltage Selector Switch at 3Ø 480/277	416V/240, 440V/254, 480V/277	N/A
1Ø Voltage (L-L/L-N) Voltage Selector Switch at 1Ø 240/120	N/A	240/120
Power Factor	0.8	1.0
Voltage Regulation (No load to full load)	±0.5%	
Generator RPM	1800	
Frequency	60 Hz	
Winding Pitch	2/3	
No. of Poles	4	
Excitation	Brushless with AVR	
Frequency Regulation: No Load to Full Load	Isochronous under varying loads from no load to 100% rated load	
Frequency Regulation: Steady State	±0.25% of mean value for constant loads from no load to full load	
Insulation	Class H	
Sound Level dB(A) Full load at 23 feet	65	

Engine Specifications

Make / Model	Isuzu / BR-4JJ1X
Emissions	EPA Tier 4 Final Certified
Starting System	Electric
Design	4-cycle, water cooled, direct injection, turbocharged, charge air cooled, DOC and SCR
Displacement	183.0 in ³ (2999 cc)
No. cylinders	4
Bore x Stroke (mm)	95.4 x 104.9
Gross Engine Power Output	95.2 hp (71 kW)
BMEP	208 psi (1434 kPa)
Piston Speed	1237 ft./min. (6.29 m/s)
Compression Ratio	16.5:1
Engine Speed	1800 rpm
Overspeed Limit	2070 rpm
Oil Capacity	3.96 gallons (15 liters)
Battery	12V 75Ah x 1

Fuel System

Recommended Fuel	ASTM-D975-No.1 & No.2-D*	
Maximum Fuel Flow (per hour)	16 gallons (60 liters)	
Maximum Inlet Restriction (Hg)	2.9 in. (73.6 mm)	
Fuel Tank Capacity	103 gallons (390 liters)	
Fuel Consumption	gph	lph
At full load	4.4	16.6
At 3/4 load	3.5	13.4
At 1/2 load	2.6	9.8
At 1/4 load	1.7	6.4
DEF Tank Capacity	7.4 gallons (28 liters)	

* Use ultra-low sulfur diesel fuel

Cooling System

Fan Load	4.7 hp (3.5 kW)
Coolant Capacity (with radiator)	5.5 gallons (21 liters)
Coolant Flow Rate (per minute)	15.9 gallons (60 liters)
Heat Rejection to Coolant (per minute)	2483 Btu (2.62 MJ)
Maximum Coolant Friction Head	1.2 psi (7.9 kPa)
Maximum Coolant Static Head	3.3 feet (1.0 meter)
Ambient Temperature Rating	104°F (40°C)

Air

Combustion Air	138 cfm (3.9 m ³ /min)
Maximum Air Cleaner Restriction	25 in. H ₂ O (6.25 kPa)
Alternator Cooling Air	526 cfm (14.9 m ³ /min)
Radiator Cooling Air	3700 cfm (105 m ³ /min)
Minimum Air Opening to Room	6.03 ft ² (0.56 m ²)
Minimum Discharge Opening	3.33 ft ² (0.31 m ²)

Exhaust System

Gas Flow (full load)	272 cfm (7.7 m ³ /min)
Gas Temperature	572°F (300°C)
Maximum Back Pressure	7.2 in. H ₂ O (17.5 kPa)

Amperage

Rated Voltage	Maximum Amps
1Ø 120 Volt	155.4 Amps (4 wire) 168A x 2 (Zigzag)
1Ø 240 Volt	77.8 Amps (4 wire) 168A (Zigzag)
3Ø 240 Volt	168 Amps
3Ø 480 Volt	84 Amps
Main Line Circuit Breaker Rating	200 Amps
Over Current Relay Trip Set Point 480V Mode Only	84 Amps

PowerBalance Load Bank

Rated Voltage	Maximum Amps
kW Rating	19.6
1Ø 240 Volt	54.4 Amps
3Ø 240/480 Volt	47.1/23.6 Amps
Fuses	60 Amps x 3

